

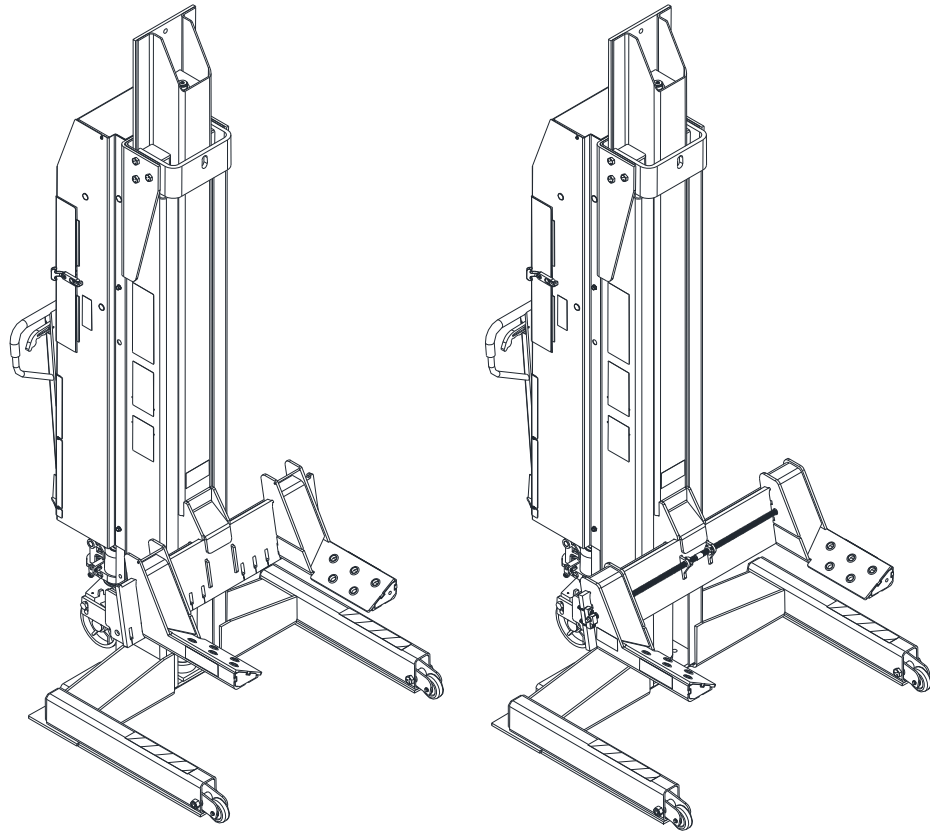

Installation, Operation & Maintenance Manual



CLHM-140, CLHM-190, & CLHM-190W **WIRELESS PORTABLE LIFT SYSTEM**

2311 South Park Rd. Louisville, Kentucky 40219

Email: sales@challengerlifts.com Web site: www.challengerlifts.com

Office 800-648-5438 / 502-625-0700 Fax 502-587-1933

**IMPORTANT: READ THIS MANUAL COMPLETELY BEFORE
INSTALLING or OPERATING LIFT**

Table of Contents

Foreword	Error! Bookmark not defined.
Signal Words	3
Receiving Inspection	3
Introduction	4
Specifications	5
Component Identification	6
1. Safety Instructions	7
2. Operating Instructions	9
2.1 Prepare the Work Area	9
2.2 Prepare the Vehicle	10
2.3 Prepare the Lift Units	10
2.4 Control Box Initialization	11
2.5 Main Operation Screen.....	13
2.6 Raising/Lowering the Vehicle	14
2.7 Locking the Lift System.....	15
2.8 Lowering the Vehicle to the Ground	15
2.9 Single/Paired Operation.....	15
2.10 Park Mode	16
2.11 Options	16
2.12 Tire Mode.....	17
2.13 Control Box Shutdown and Restart Procedure.....	17
3. FCC Part 15 Statement for User's Manual	18
4. Moving the Lift Unit in the Work Area	19
4.1 Moving the Lift Unit with the Handle	19
4.2 Moving the Lift Unit with a Forklift.....	19
5. Battery Information	Error! Bookmark not defined.
5.1 Battery Type	20
5.2 Charging the Battery.....	20
5.3 Battery Life.....	22
5.4 Battery Maintenance.....	22
5.5 Critical Battery Level Detected Message.....	22
6. Emergency Procedures	23
6.1 Emergency Stop	23
6.2 Manual Lowering	23
7. Lifting Multiple Vehicles in the Same Work Area	24
8. Adjusting Carriage Width	25
8.1 Standard Width Models	25
8.2 Wide Model.....	25
9. Maintenance Instructions	26
9.1 Monthly Maintenance Requirements	26
9.2 Adding Hydraulic Fluid.....	26
9.3 Bleeding Air from Hydraulic Cylinder	26
9.4 Down Stop Catch Pawl Lubrication	27
9.5 Down Stop Catch Pawl Adjustment	28
9.6 Carriage Width Adjustment Mechanism Lubrication (<i>Wide Model Only</i>).....	29
9.7 Electrical Fuses	30
10. Structural Inspection	31
11. Troubleshooting	32

Signal Words

Signal words call attention to a safety message or messages, or a property damage message or messages, and designate a degree or level of hazard seriousness. The signal words are “DANGER”, “WARNING”, “CAUTION”, and “NOTICE”.

DANGER: Indicates a hazardous situation, which, if not avoided, will result in death or serious injury. This signal word is to be limited to the most extreme situations.

WARNING: Indicates a hazardous situation, which, if not avoided, could result in death or serious injury.

CAUTION: Indicates a hazardous situation, which, if not avoided, could result in minor or moderate injury.

NOTICE: Indicates a hazardous situation, which, if not avoided, could result in non-personal injury.

Receiving Inspection

Completely remove all tape and packaging. Inspect each lift unit immediately upon delivery. If shipping damage is evident, inform the delivering carrier immediately and contact the manufacturer using the contact information on the back cover of this manual.

Introduction

Owner and/or Operator Responsibilities

WARNING

All personnel involved in the use and operation of this lift system must be careful, competent, trained, and qualified in the safe operation of this equipment and its proper use when servicing motor vehicles and their components. It is the responsibility of the employer, owner, and/or manager to ensure that all personnel working with and around the lift system know what they are doing, both during normal operation and in emergency situations. To ensure all personnel are properly trained and qualified, the following items must be done prior to using the lift system:

- ❖ All personnel must know and understand all lift system instructions and warnings before working with or around these lift units. “All personnel” includes lift system operators as well as people working on or in the vicinity of vehicles raised by the lift system.
- ❖ All personnel must read and understand the contents of the lift system manual. If any personnel are illiterate or not fluent in English, the employer, owner, and/or manager must read and discuss the lift system instructions and warnings with them in a language they understand, making sure that all personnel know this information and observe the proper procedures for use of these lift units.
- ❖ The employer, owner, and manager are responsible for maintaining the lift system manual and all on-product labeling. Labeling should be legible and intact at all times. The lift system manual must be readily available to all personnel. Contact the manufacturer to receive replacement labeling. Replacement (or extra) copies of the manual are available from the manufacturer.
- ❖ The employer, owner, and manager must enforce safe work practices with the lift system in order to ensure that personnel not only know how to use the lift system safely, but also that they actually **do** what they should.
- ❖ As part of training, the employer, owner, and manager should have all personnel practice normal and emergency operating procedures without loads prior to using the lift system to raise loads.

This lift system is **not** a product that personnel can just “figure out” on their own. This lift system has been designed to be easy to use, but it requires thoroughly trained and knowledgeable personnel to use it safely. Failure to operate this lift system according to the warnings and instructions can result in **severe injury or death**.

Specifications

Model	WPLS-140	WPLS-190	WPLS-190W
Max. Capacity per Unit	14,000 lb. (6,350 kg)	19,000 lb. (8,618 kg)	19,000 lb. (8,618 kg)
Max. Hydraulic System Operating Pressure	2,180 psi (15.0 MPa)	2,600 psi (17.9 MPa)	2,600 psi (17.9 MPa)
Minimum Wheel Diameter	5.0 in. (127 mm)	5.0 in. (127 mm)	4.0 in. (102 mm)
Maximum Wheel Diameter	24.5 in. (622 mm)	24.5 in. (622 mm)	No max.- Determined by tire diameter
Maximum Tire Diameter	N/A	N/A	53.0 in. (1,346 mm)
Maximum Lift Height (2 units-Normal Mode)	32 in. (813 mm)	32 in. (813 mm)	32 in. (813 mm)
Maximum Lift Height (4 or more units)	69 in. (1,753 mm)	69 in. (1,753 mm)	69 in. (1,753 mm)
Lift Speed (Max. Load)	60 in./min. (1,524 mm/min)	60 in./min. (1,524 mm/min)	60 in./min. (1,524 mm/min)
Weight of Lift Unit	1,485 lb. (674 kg)	1,510 lb. (685 kg)	1,575 lb. (714 kg)
Footprint of Lift Unit	560 in ² (3,613 cm ²)	560 in ² (3,613 cm ²)	600 in ² (3,871 cm ²)
Ground Pressure for each Lift Unit (Max. Load)	27.7 psi (191 kPa)	36.6 psi (252 kPa)	34.3 psi (236 kPa)
Height of Lift Unit	88.5 in. (2,248 mm)	88.5 in. (2,248 mm)	88.5 in. (2,248 mm)
Height of Lift Unit at Full Lift	157.13 in. (3,991 mm)	157.13 in. (3,991 mm)	157.13 in. (3,991 mm)
Width of Lift Unit	44.25 in. (1,124 mm)	44.25 in. (1,124 mm)	49.0 in. (1,245 mm)
Length of Lift Unit	53.63 in. (1,362 mm)	53.63 in. (1,362 mm)	53.63 in. (1,362 mm)
Turning Radius of Lift Unit	47.0 in. (1,194 mm)	47.0 in. (1,194 mm)	47.0 in. (1,194 mm)
Operating Peak Power	4.0 hp (3.0 kW)	4.0 hp (3.0 kW)	4.0 hp (3.0 kW)
Operating Voltage	24 VDC Nominal	24 VDC Nominal	24 VDC Nominal
Charger Voltage Required	70-130 VAC @ 50-60 Hz	70-130 VAC @ 50-60 Hz	70-130 VAC @ 50-60 Hz
Charger Amperage Required	1.3 Amps	1.3 Amps	1.3 Amps

Component Identification

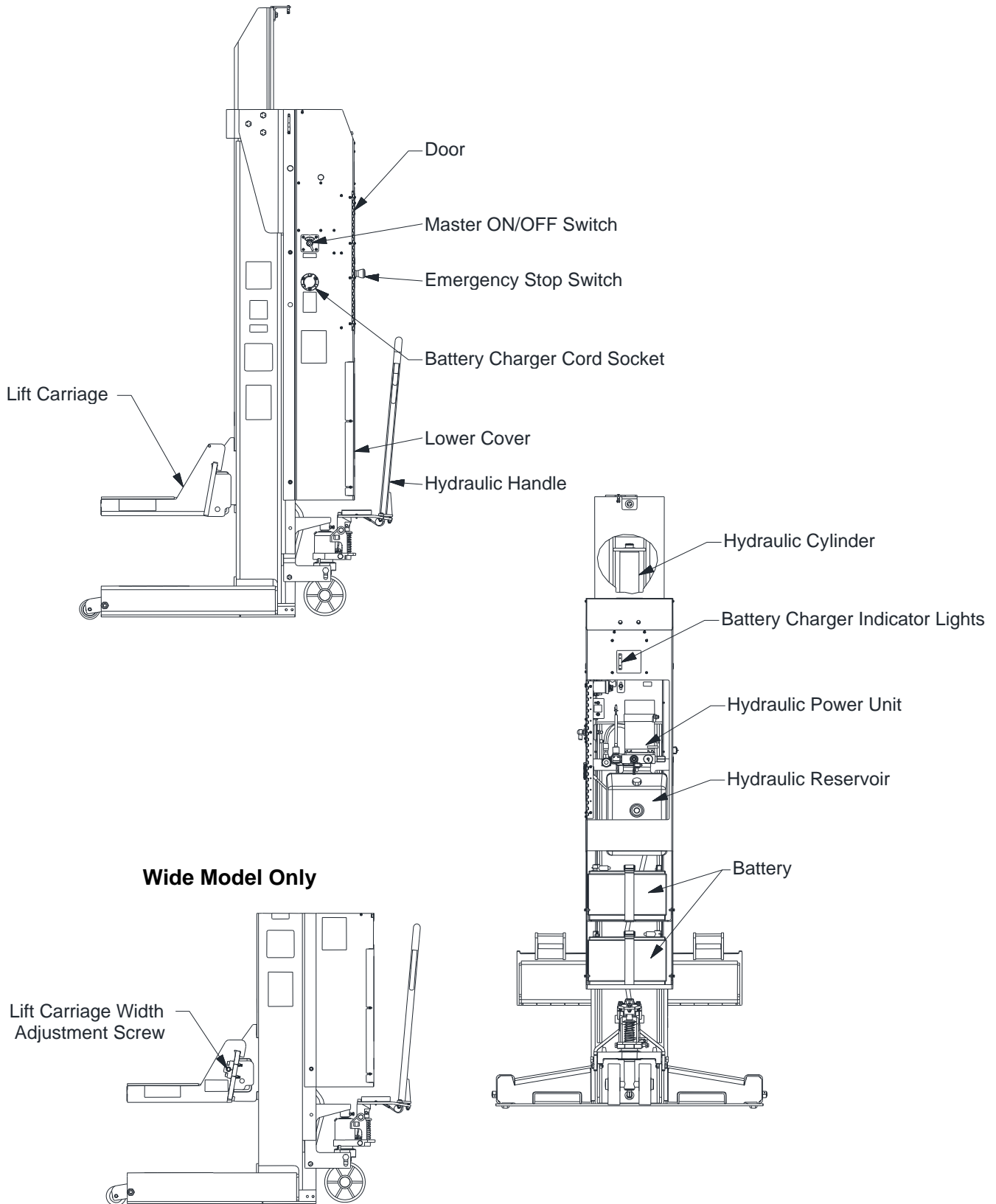

1. Safety Instructions

Read all instructions in this manual before operating the lift unit to avoid **severe injury** or **death**. All of the steps and procedures in this manual relate to the safe use of the lift system. Contact the manufacturer using the contact information on the back cover of this manual if you have any questions about this unit or its instructions and warnings. **DO NOT** use this product unless you know exactly what you are doing and are sufficiently trained and capable of using the lift system safely (see the Warnings on page 4). When using the lift system, always adhere to basic safety precautions, including the following:

⚠ WARNING

Failure to know, understand, and obey the procedures, instructions and warnings contained in this manual could result in **severe injury** or **death**.

- ❖ **DO NOT** use the lift system to raise a vehicle by the frame or structural member. Lift vehicles with the lift system only by the vehicle's wheels (except when using manufacturer supplied special-purpose adapters for their intended application).
- ❖ The lift system is to be used only in sets of 2, 4, 6, or 8 lift units –**NEVER** as a single lift unit. The only exception to this requirement is when using a single unit in Tire Mode as described in Section 2.12. **Lift only on the same axle.**

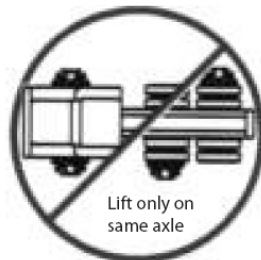

- ❖ **DO NOT** raise or lower one side of a vehicle (except when using Tire Mode). Lift units should **ALWAYS** be used in pairs to lift wheels on opposite ends of the same axle.
- ❖ **DO NOT** raise one end of a vehicle if the opposite end is supported by stands or another lifting device. When using two lift units to raise one end of a vehicle, the opposite end of the vehicle must be in contact with the ground, transmission in neutral and parking brake released. The only exception to this requirement is when using the lift system in single or paired mode as described in Section 2.9 of this manual.
- ❖ **DO NOT** use the lift system in conjunction with any other equipment used to raise a vehicle (e.g., any other jacks or lifts that are not part of the lift system).
- ❖ **DO NOT** use blocks, non-factory supplied adapters or cribbing devices with the lift system.
- ❖ No alterations shall be made to this product except those explicitly discussed in this manual (e.g., use of optional adapters).
- ❖ **DO NOT** place hands, feet, other body parts, or clothing between the lift carriage and the column. There are potential pinch points that can injure hands and fingers or possibly grab clothing and pull body parts into pinch points.
- ❖ **NEVER** stand under the load or vehicle when it is being raised or lowered.
- ❖ To reduce the risk of fire, do not operate equipment in the vicinity of open containers of flammable liquids (gasoline).
- ❖ To reduce the risk of electric shock, do not use on wet surfaces or expose to rain.

⚠ CAUTION

- ❖ DO NOT use the lift system as a wheel dolly or for any other purpose than raising vehicles by the wheels (except when using manufacturer supplied special-purpose adapters for their intended application).
- ❖ Always keep the covers closed on the lift units.
- ❖ Care must be taken as burns can occur from touching hot parts.
- ❖ Do not operate equipment with a damaged cord or if the equipment has been dropped or damaged – until it has been examined by a qualified service man.
- ❖ If an extension cord is necessary, a cord with a current rating equal to or more than that of the equipment should be used. Cords rated for less current than the equipment may overheat. Care should be taken to arrange the cord so that it will not be tripped over or pulled.
- ❖ Adequate ventilation should be provided in the work area.
- ❖ Keep hair, loose clothing, fingers, and all parts of body away from moving parts.
- ❖ Use only as described in this manual. Use only manufacturer's recommended attachments.
- ❖ ALWAYS WEAR SAFETY GLASSES. Everyday eyeglasses only have impact resistant lenses, they are NOT safety glasses.

NOTICE

- ❖ Maximum capacity for an individual lift unit is listed on the lift unit's ID decal. DO NOT overload any individual lift unit in the lift system.
- ❖ Do not let cord hang over edge of table, bench, or counter or come in contact with hot manifolds or moving fan blades.
- ❖ Never use the cord to pull the plug from the outlet. Grasp plug and pull to disconnect.
- ❖ Let equipment cool completely before putting away.
- ❖ The optimal operating ambient temperature range is 41-104°F (5-40°C). Use of lift units outside this temperature range may result in degraded performance and reduced service life.

SAVE THESE INSTRUCTIONS

2. Operating Instructions

2.1 Prepare the Work Area

It is important that the surrounding area be properly chosen and prepared before raising a load. Refer to ANSI/ALI ALIS for additional information.

- a. Use the lift system only on hard surfaces capable of safely supporting the load. The surface must be strong enough to support the weight of the lift units and the vehicle being raised. The ground pressure for each lift unit is listed in the Specifications section. The ground pressure listed assumes the entire footprint of the lift unit is in full contact with the floor.
- b. Use the lift system only on level, even surfaces. A level surface is considered to be 3° slope or less. A surface with 3° slope is equivalent to a 5% grade or 5/8 in. (15.9 mm) rise or drop per horizontal foot (304.8 mm) as shown below. The surface must also be free of ripples, ridges, depressions, holes, or any undulation (e.g., a seam in a concrete floor) that would cause only part of the lift unit's footprint to be in contact with the floor.

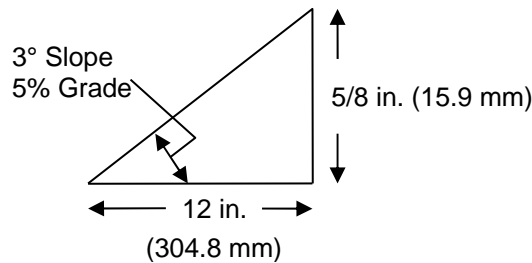

- c. Make sure there is adequate clearance above the highest point of the vehicle (including things like vehicle exhaust pipes, air dams, etc.) so the vehicle does not contact any overhead objects when raised (e.g. ceiling/roof structural components, duct work, hanging lights, heating/AC units, etc.). The lift system can raise a vehicle as much as 69" (1,753 mm) (when four or more units are used together), but the vehicle will extend vertically above this. The height of the lift unit alone (at maximum lift height) is 157.13" (3,991 mm).
- d. Clear the work area (especially the area underneath the lift unit) of any unnecessary personnel, tools, equipment and other materials. No unauthorized personnel should be allowed in the work area where the lift system is being used.
- e. If the lift system is used outdoors the operator assumes all risk. Understanding that these are portable lifts, it is foreseeable that they can and will be used outdoors. **WARNING!** *If lift units are used outdoors the following conditions must be met:*
 - *Do NOT use lift units when wind speeds or gusts exceed 20 mph to avoid tipping or loss of load.*
 - *Do NOT leave lift units unattended when used outdoors to avoid inadvertent operation by untrained operators and unforeseen changes in weather conditions.*
 - *Do NOT use lift units outdoors when precipitation of any type is falling or expected during the time the units will be used. There is a risk of electric shock if lift units are used while precipitation is falling.*
 - *Do NOT charge lift units while outdoors. Only charge lift units while indoors to avoid risk of electric shock.*

If these conditions cannot be met, move the vehicle and lift units (separately) to an indoor area where the lifting operation can be performed safely. **WARNING!** *NEVER attempt to move or reposition a lift unit when a vehicle is raised on the lift unit.*

2.2 Prepare the Vehicle

It is important that the vehicle be in proper condition before raising it off the floor.

- a. The vehicle's wheels (or rims; not the tires) must meet the minimum wheel diameter requirement shown in the Specifications section on page 5 or else they could fall through the cradle of the lift carriage (for example, if the tires deflate). See Section 2.3 for information about how to properly engage a tire.
- b. Check that the tires on the vehicle are properly inflated and are in road-worthy condition. Make sure the weight on any single tire does not exceed the rated capacity of its lift unit, as the total weight of the vehicle may not be evenly distributed across all lifted tires. Also, be sure to consider the weight carried by unsupported axles (i.e. a set of 4 lift units used to raise a vehicle with three axles).

2.3 Prepare the Lift Units

It is important to prepare the lift units so they can be used safely together.

- a. Make sure to use an appropriate number of lift units for the type and weight of the vehicle to be lifted. Determine how many lift units will be needed to raise the vehicle by calculating the weight of the vehicle and the load applied to each lift unit when the vehicle is raised. NEVER exceed the rated capacity of an individual lift unit. Also, the lift system is to be only used in sets where lift units are positioned on opposite ends of the same axle– NEVER as a single lift unit or on only one side of a vehicle unless using Tire Mode as described in Section 2.12.
- b. Before each use, you should inspect each lift unit for any visible signs of wear or damage. See the Section 10 for details about how to inspect the lift unit. **WARNING!** *If you see any signs of wear or damage, or if there is any indication that the lift unit is not performing normally, immediately take it out of service and contact the manufacturer. NEVER use a lift unit that appears damaged in any way.*
- c. Before each use, plug in each lift unit and make sure the battery charger indicator light is green for both batteries on each lift unit (see Section 5.2 of this manual). If the light is not green, charge the battery until the battery charger indicator light is green. Failure to fully charge the battery before use can reduce the life of the battery.
- d. Transport the lift units to the work area by either wheeling them manually or lifting and transporting them with a forklift (see Section 4 on page 19). A lift unit can be wheeled to the work area over smooth, level surfaces for short distances. Transport the lift units by forklift if traveling over longer distances and/or rough or uneven surfaces.
- e. Position the lift units at opposite ends of the same axle. If necessary, adjust the carriage lift arms (See Section 8) until they are wide enough to allow the lift pads to clear the tire tread. Make sure the lift pads cradle the tires evenly and are aligned with the tire. Position the lift pads under the tire so the entire lift pad is under the tire (see Figure 1). Lower the base to the ground using the handle once the lift unit is properly positioned (see Section 4 for more information).
WARNING! *The carriage lift arms must be positioned so they are centered on the lift carriage. NEVER use the lift unit with the lift arms positioned in an off-center position since this can cause dangerous side loading of the lift unit.*
- f. Place the vehicle transmission in neutral and release the parking brake.

Figure 1. Tire Engagement

Correct- Carriage Lift Pads Properly Engaged

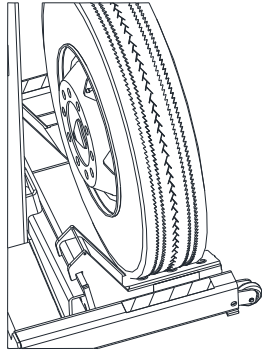

Incorrect- Carriage Lift Pads Not Fully Engaged

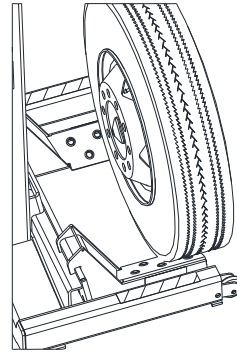

2.4 Control Box Initialization

- Make sure the master on/off switch (see the “Component Identification” section on page 6) on all lift units is turned to the **OFF** position.
- Turn the master on/off switch of the first lift unit to the **ON** position. The green colored touch screen power indicator light located just below the screen should turn on once the master on/off switch is turned **ON**. It will take 15-20 seconds for the touch screen to completely start up and be ready to use. The Home screen will be shown with a series of icons on the screen. Select the Lift Program icon to start the program used to lift a vehicle. **NOTE:** After completing startup the screen may automatically change to the Lift Program screen. If this occurs, then the step of selecting the Lift Program icon can be skipped.
- The control box will initialize and then the screen shown below will appear on the touch screen. (**NOTE:** All screens shown in this manual are simplified versions of what is actually shown on the display to help clarify button locations and functions.)

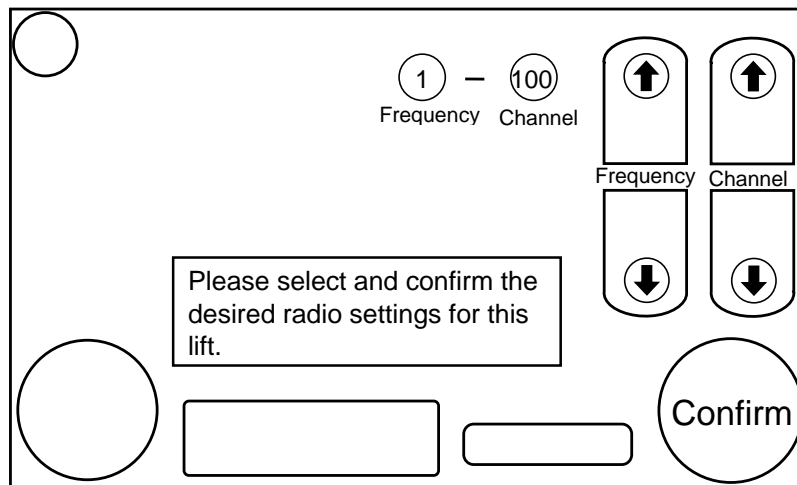

- Select the desired radio settings. The default radio settings will be the settings selected the last time the unit was used. Push the up and down arrows on the right side of the screen to change the radio frequency and/or channel, if needed. All units that will be used together as a lift system to lift a vehicle must be set to the same frequency and channel. There are 12 radio frequencies available for use and the channel can range from 100-120 for each frequency. Refer to Section 7 for more information on selecting the radio settings. When the desired radio settings are shown, push the **Confirm** button to advance to the next screen. **NOTE:** Do not rush and push the **Confirm** button before the control box has completely initialized. Wait until the radio settings update to show the previously used settings before pushing the **Confirm** button.

- e. Read through the Notice that is displayed on the next screen. If the operator agrees with and acknowledges the statements made on the screen, push the **Accept** button to continue setting up the lift system.
- f. The display then changes to ask how many lift units will be part of the lift system. Push the button that corresponds with the total number of lift units that will be used in the current lifting system.
- g. A screen will now appear asking which operating mode will be used. Select the desired operating mode from the list of modes displayed. If the vehicle is being lifted by the tires using the standard lift arms select **Normal Mode**. Only select one of the adapter modes if using a manufacturer supplied adapter. See the Owner's Manual supplied with the adapter for complete operating instructions. **WARNING!** *Use of the wrong operating mode can result in serious injury, death, and/or property damage due to a vehicle tipping or falling from the lift system. ONLY use one of the adapter modes when the correct manufacturer supplied adapter is properly installed on the lift unit.*
- h. The display will now appear as shown below with a picture of a vehicle asking for the current lift unit's position relative to the vehicle. Select the round button with a number inside it that matches the current lift unit's position. Once the position is selected the position button will turn green to indicate the selection.

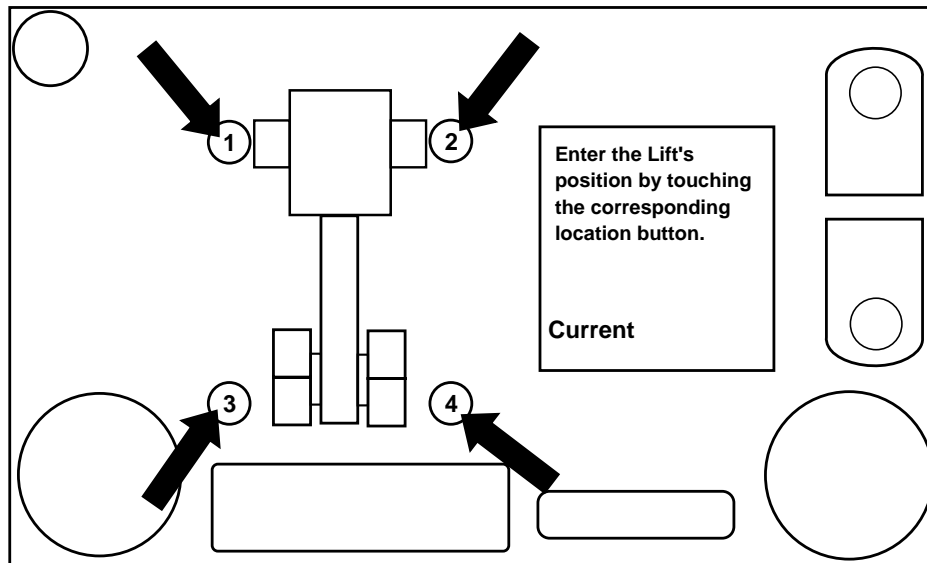

- i. Now move to the second lift unit (the units can be turned on in any order) and turn the master on/off switch to the **ON** position. The same screen shown in Step (c) above will appear after the screen has completed its startup.
- j. Select the same radio frequency and channel as was chosen in Step (d) by pushing the up and down arrows on the right side of the screen. When the correct radio settings are shown, push the **Confirm** button.
- k. The display will now show the same screen as shown in Step (h) above. Select the round button that matches the position of the current lift unit relative to the vehicle. Positions that have already been selected will be shown by a yellow colored button.
- l. Repeat Steps (i) through (k) on all remaining units that will be used in the current lifting system.
- m. If operating in **Normal Mode**, once all the units in the lifting system are initialized (radio settings and position relative to the vehicle selected) the screen on all units will appear as shown below. Some of the adapter modes will show a different screen that requires additional setup before lifting the vehicle. If any error messages are shown during initialization consult Section 11.

2.5 Main Operation Screen

The screen shown below is the main operation screen. There are several buttons and indicators present on this screen. See the table below for an explanation of each button or indicator on the main screen. Several of these buttons and indicators are also shown on other screens and they perform the same functions on those screens as well. After reviewing this section, proceed to one of the following sections to perform the desired function with the lift system.

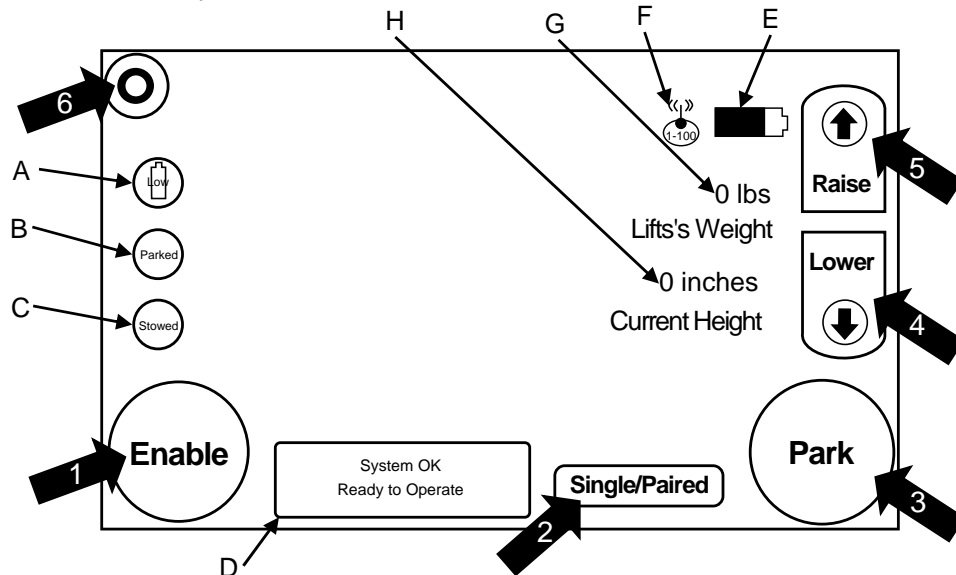

Button	Name	Function
1	Enable	Once pushed and released allows the lift system to raise/lower. Must be ON (green) before any operation that will raise/lower the system. Button remains ON (green) for 5 seconds after being pushed.
2	Single/Paired	Begin Single/Paired operation of the lift system. See Section 2.9 for further details.
3	Park	Park the lift system so the load is mechanically supported on the down stop lugs. See Section 2.10 for more information.
4	Lower	When this button is pushed the lift system will lower until the button is released. The Enable button must be pushed, released, and be ON (green) for the system to lower. See Section 2.6.
5	Raise	When this button is pushed the lift system will raise until the button is released. The Enable button must be pushed, released, and be ON (green) for the system to raise. See Section 2.6.
6	Options	Brings up menu with additional functions. See Section 2.11 for details.
Indicator	Name	Function
A	Low Battery	Illuminates when battery voltage drops to a low level while raising or lowering indicating the battery needs to be charged.
B	Parked	Illuminates when the unit is parked and the load is supported on the down stop lugs.
C	Stowed	Illuminates when all lift units in the system are fully lowered.
D	Message Panel	Displays messages indicating system status.
E	Battery Charge Level	Shows the current charge level of the batteries. This indicator will not update while the lift is raising or lowering.
F	Radio Settings	Displays the radio frequency and channel that the lift unit is using.
G	Weight	Displays the amount of weight lifted by the lift unit. The weight is only accurate when the vehicle is stationary.
H	Height	Displays the current height of the lift unit

2.6 Raising/Lowering the Vehicle

Once the work area, vehicle, and lift units are prepared perform the following steps:

- a. Position yourself at any one of the lift units.
- b. Push and release the **Enable** button. The button color will change from red to green indicating the button is ON. The button will stay ON (green) for 5 seconds after it is released. If no other buttons are pushed during the 5 seconds the button will automatically turn OFF (red) at the end of the 5 seconds.
- c. During the 5 seconds that the Enable button is ON (green), push and hold the **Raise** or **Lower** button to raise or lower the vehicle. **NOTE:** During lowering the vehicle will automatically lower at a slower speed for the first 6 inches of travel. This slow start feature allows the vehicle to be gently placed on stands. After the first 6 inches of travel the vehicle will lower at normal speed for the remainder of time the **Lower** button is pushed.
- d. As the vehicle raises or lowers the height and weight indicators on the screen will update to show the current values. **NOTE:** The weight shown is only accurate when the lift unit is not raising or lowering.
- e. When the vehicle is at the desired height release the **Raise** or **Lower** button.
- f. If desired, Park mode can be activated on the lift unit to mechanically support the load on the down stop system and relieve the hydraulic system pressure. Follow the steps in Section 2.10 to activate Park mode. **NOTE:** Even if Park mode is not activated the down stop system will automatically stop the load from lowering should the hydraulic system lose pressure.
- g. Depending on the amount of time the vehicle will remain in the current position the lift system should be either locked or turned off. If the vehicle will be raised or lowered before the end of the shift, the lift system should be locked by following the steps in Section 2.7. If the vehicle will be left in the raised position longer than 8 hours, turn the master on/off switch on all lift units in the system to the **OFF** position to conserve the batteries.

WARNING! *There are several important safety issues to consider when raising a vehicle or whenever a vehicle is in a raised position, including:*

- ❖ *All personnel should be instructed that the system should not be unlocked or restarted unless all objects and personnel are out from underneath the vehicle and the vehicle, work area, and lift units are prepared for lifting or lowering.*
- ❖ *If the lift units are to be removed from a raised vehicle, use only stands intended for this purpose. Use appropriate vehicle support stands when a raised vehicle is to be left elevated for an extended amount of time. Appropriate stands must be capable of supporting the load and they must be made specifically for high-rise supporting.*
- ❖ *NEVER attempt to climb up, climb on, or get in a raised vehicle. Do not open the vehicle's doors or make adjustments to the exterior when raised, as it could interfere with safe lowering of the vehicle.*
- ❖ *NEVER start the vehicle's motor when it is supported by the lift units or stands. Only start the engine when the vehicle is firmly in contact with the ground and the lift units have been removed from the wheels.*
- ❖ *NEVER attempt to move a vehicle horizontally by any means when it is raised on the lift system. Once the vehicle is raised, it should only be moved up or down. Also, NEVER attempt to move or reposition a lift unit when a vehicle is raised on the lift unit.*
- ❖ *NEVER subject a lift unit to dynamic loading (i.e. "shock loading"). NEVER add objects or other weight to the vehicle once it has been raised on the lift units.*

If you experience any problems while raising the vehicle or while it is raised, consult Section 6 on page 22 and/or Section 11 on page 32 of this manual.

2.7 Locking the Lift System

- a. Push the Options button (gear shaped button in the top left corner of the screen).
- b. After the menu appears on the left side of the screen select the padlock button in the middle.
- c. A message will appear asking whether or not Password Lock will be used. If **No** is selected then the system will display a message showing it is now locked. If **Yes** is selected then a prompt will appear to create a password that will be required to unlock the system. Enter a password and push **OK**. The system should now display a message showing the system is locked.
- d. When ready to unlock the system, return to the unit where the lock button was pushed (shown by the flashing yellow position indicator) and push the **Reset** button. If Password Lock was not used the system will now be unlocked. If Password Lock was used then the same password created in step c will need to be entered to unlock the system.

2.8 Lowering the Vehicle to the Ground

WARNING! *To avoid serious injury or death, NEVER drive the vehicle off the lift units or attempt to move a vehicle that is elevated by the lift system.*

- a. Clear the work area under the vehicle of all personnel, tools, and equipment. Make sure there are no obstructions under the vehicle or under the lift carriages of the lift system prior to lowering the vehicle to the ground.
- b. If the lift system was locked, unlock the system by following the steps in Section 2.7. If the lift system was turned off, follow the steps in Section 2.4 to reinitialize the system. If Park mode was activated, refer to Section 2.10 prior to lowering the vehicle.
- c. Position yourself at any one of the synchronized lift units.
- d. Push and release the **Enable** button. The button color will change from red to green indicating the button is ON. The button will stay ON (green) for 5 seconds after it is released. If no other buttons are pushed during the 5 seconds the button will automatically turn OFF (red) at the end of the 5 seconds.
- e. During the 5 seconds that the Enable button is ON (green), push and hold the **Lower** button to lower the vehicle.
- f. Release the **Lower** button when the vehicle is lowered to the floor and the lift carriages no longer contact the tires. This condition will be indicated when the **Stowed** indicator turns blue.
- g. Place the vehicle's transmission in gear (or park) and engage the vehicle's parking or air brake.
- h. Move the lift units away from the work area and turn the master on/off switch to the **OFF** position. About 10 seconds after the master on/off switch is turned **OFF** the screen will display a message and power down. This will ensure the lift units are ready to be synchronized for lifting in the future and conserve the batteries while the lift system is not in use.
- i. Completely recharge each lift unit after use.

2.9 Single/Paired Operation

In some situations it may be desirable to place only one wheel or one axle on stands instead of placing the entire vehicle on stands. The lift system features a special mode of operation called single/paired mode to allow this. The system can be placed in single/paired mode at any height.

- a. If only one wheel of the vehicle will be placed on a stand, position yourself at the lift unit that is positioned on that wheel of the vehicle. If one axle will be placed on stands, position yourself at one of the lift units on the ends of the axle to be supported.
- b. Push the **Single/Paired** button on the main operation screen shown in Section 2.5.
- c. A screen will appear asking whether the system will be operated in single mode or paired mode. If only one wheel will be supported on stands push the **Single** button. If one axle will be

supported on stands push the **Paired** button. Pushing the **Exit** button will return to the main operation screen.

- d. The screen shown below (paired mode is shown in this example, single mode would be similar) will be displayed on the lift unit where single or paired mode was initialized. All other lift units will be locked out from operation and show a screen indicating this condition.

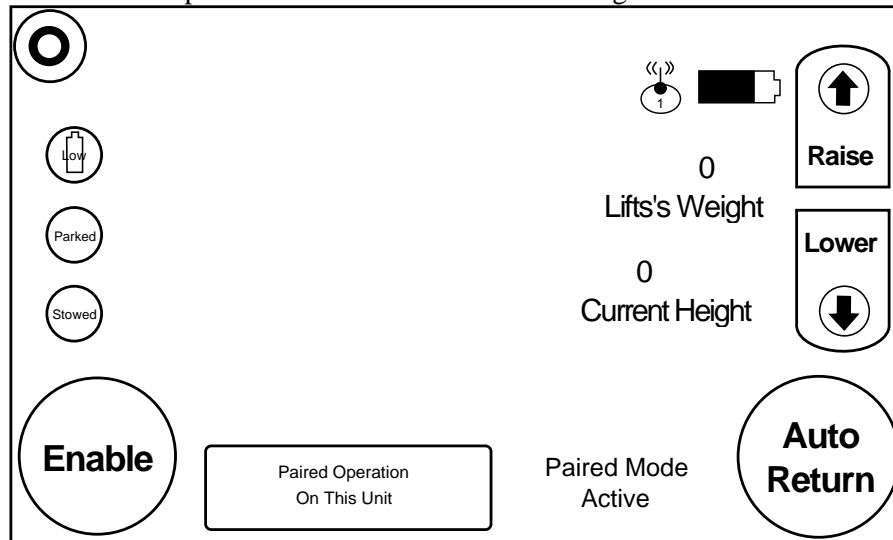

- e. All the buttons shown function in the same way as described in Sections 2.5 and 2.6. The vehicle can be raised or lowered as needed to place stands and support the vehicle. The distance the vehicle can be raised or lowered is limited while in single or paired mode.
- f. When all work that required the wheel/axle to be supported on a stand(s) has been completed, move the lift unit(s) back into position under the wheel(s). The lift unit(s) can be raised or lowered to help with properly positioning the lift carriage under the wheel(s). Push and release the **Enable** button and then within 5 seconds push and release the **Auto Return** button. The lift unit(s) that was raised or lowered in single or paired mode will automatically adjust its height to match the other units in the system and support the vehicle.
- g. Once the lift unit(s) has adjusted its height to match the rest of the system, all the screens will return to the screen shown in Section 2.5. The system will now operate as a whole with all lift units raising or lowering together.

2.10 Park Mode

If desired, the load on the lift carriage can be transferred from the hydraulic cylinder to the mechanical down stop system by activating Park mode. The following steps explain how to activate Park mode.

- Follow the steps in Section 2.6 to position the vehicle at the desired working height.
- Push and release the **Enable** button and within 5 seconds push and release the **Park** button. The lift system will now lower until the down stop catch pawl engages the down stop slots on all lift units in the system.
- Once all the units in the system have Parked, the **Parked** indicator will turn blue. The **Lower** button and **Park** button will also disappear since the vehicle will need to be raised off the down stop catch pawl before it can be lowered.
- To exit Park mode, simply push and release the **Enable** button and then within 5 seconds push and hold the **Raise** button until the **Parked** indicator light turns off. The vehicle can now be raised or lowered normally.

2.11 Options

The **Options** button displays additional buttons that are normally hidden from view on the screen. Pushing the **Options** button displays a panel on the left side of the screen that includes the **Lock** button and the

About button. To hide the panel that is displayed when the **Options** button is pushed, push the **Back** button.

The **Lock** button is used as described in Section 2.7 to lock the system from operating. Pushing the **About** button brings up a screen showing the contact information for the lift system manufacturer, the software versions currently installed, and the battery voltage. To exit the About screen push the **Back** button.

2.12 Tire Mode

Tire mode is a special operating mode that must only be used to change a tire on a vehicle with dual axles. Tire mode allows a single lift unit to raise to a limited maximum height. To use Tire Mode properly the following steps must be followed:

- The vehicle to be lifted must have dual axles.
- The tire to be changed must be on one of the dual axles.
- The lift unit must engage the wheel in front or behind of the tire to be changed on the same side of the vehicle as the tire being changed. Chock the front and rear of the tire on the opposite end of the axle from the tire being changed.
- Follow the guidelines in Sections 2.1-2.3 to setup the work area, vehicle, and lift unit.
- Activate Tire Mode by pushing the tire icon shown below.

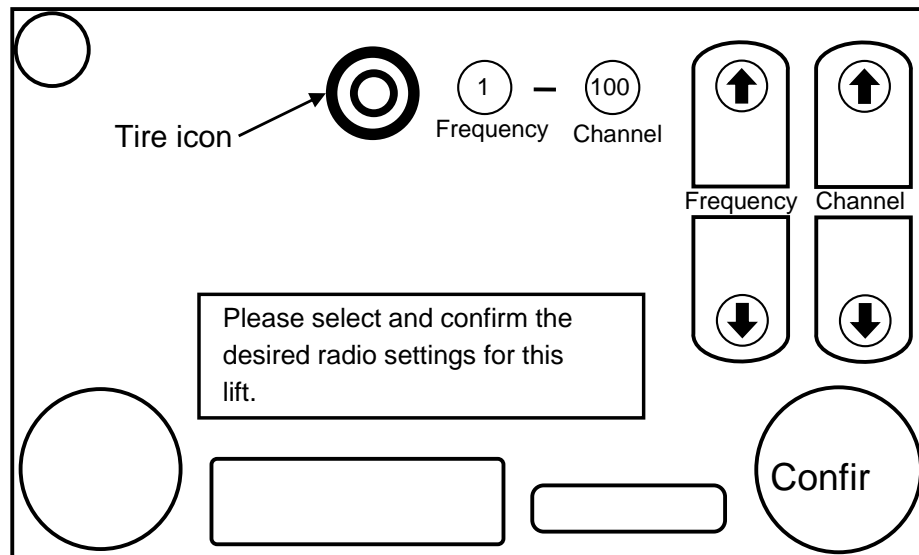

- The lift unit can now be operated as described in earlier sections. The lift can be raised, lowered, parked, and locked. The maximum lifting height is limited to prevent lifting the vehicle too high causing it to become unstable.

WARNING! Using Tire Mode for any other purpose than what is described in this section may cause a vehicle to be lifted in an unstable manner resulting in tipping or loss of load. Tire mode must ONLY be used exactly as described in this section. Failure to heed this warning could cause serious personal injury and/or property damage.

2.13 Control Box Shutdown and Restart Procedure

The control box consists of two main parts- the control board and the touch screen which is an Android tablet computer. Just like any computer the touch screen will need to be restarted (rebooted) if it operates abnormally. Additionally, the control box should be shut down when the lift is not in use to conserve the batteries. Follow the steps below to shutdown and restart the control box.

- To shut down the control box turn the master on/off switch on the side of the lift unit to the OFF position. After about 10 seconds a message will be displayed and the screen will power down. The green touch screen power indicator light will also turn off once the control box has fully powered down. **NOTE:** Do not restart the control box until the green touch screen power

indicator light has turned off or else problems may be experienced when the control box restarts. If the control box does not power down after waiting at least 10 seconds then the screen reset button shown in Figure 2 can be pushed and released to turn off the control box.

- b. To restart the control box turn the master on/off switch to the ON position. The touch screen will automatically turn on and the green touch screen power indicator light will turn on to indicate the control box is on even though nothing may be shown on the screen. After 15-20 seconds the control box will be completely restarted and ready for use.

Figure 2. Touch Screen Power Indicator Light and Screen Reset Button Locations

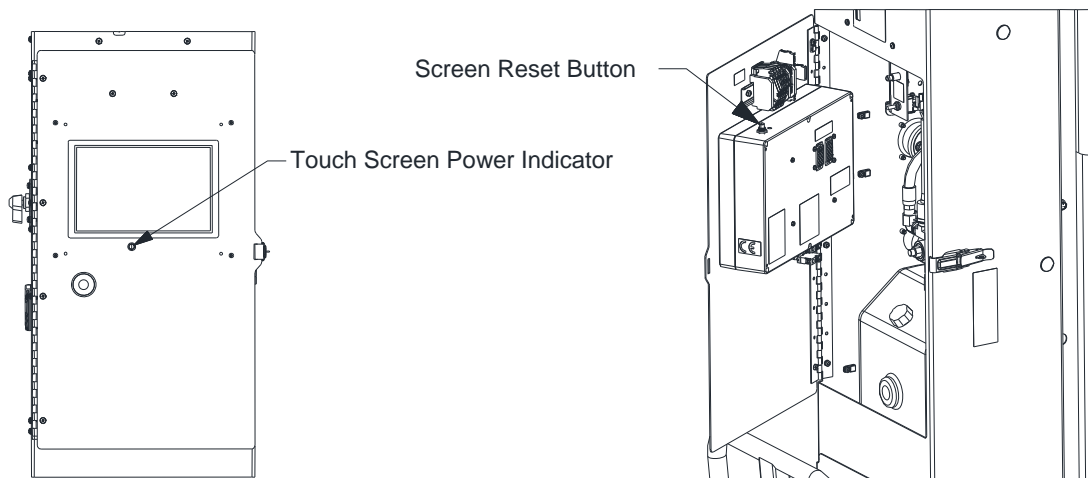

3. FCC Part 15 Statement for User's Manual

This device complies with Part 15 of the FCC rules. Operation is subject to the following two conditions:

- (1) This device may not cause harmful interference, and
- (2) This device must accept any interference received, including interference that may cause undesired operation.

WARNING! Changes or modifications not expressly approved by the party responsible for compliance could void the user's authority to operate this equipment.

NOTE: This equipment has been tested and found to comply with the limits for a Class B digital device, pursuant to Part 15 of the FCC Rules. These limits are designed to provide reasonable protection against harmful interference in a residential installation. This equipment generates, uses, and can radiate radio frequency energy and, if not installed and used in accordance with the instructions, may cause harmful interference to radio communications. However, there is no guarantee that interference will not occur in a particular installation. If this equipment does cause harmful interference to radio or television reception, which can be determined by turning the equipment off and on, the user is encouraged to try to correct the interference by one or more of the following measures:

- Reorient or relocate the receiving antenna.
- Increase the separation between the equipment and receiver.
- Connect the equipment into an outlet on a circuit different from that to which the receiver is connected.
- Consult the dealer or an experienced radio/TV technician for help.

4. Moving the Lift Unit in the Work Area

If a lift unit needs to be moved in the work area, either move it manually (with the handle and wheels) or with a forklift. A lift unit can be manually wheeled to the work area over smooth, level surfaces for short distances. **WARNING!** *Jolting caused by the lift unit's wheels catching on uneven surfaces can cause physical strain and personal injury. A lift unit should be transported by forklift if traveling over longer distances and/or rough or uneven surfaces. A forklift must also be used if the lift unit is being removed from a pallet (e.g., when the lift unit is shipped to the customer).*

4.1 Moving the Lift Unit with the Handle

To move the lift unit for positioning, push down on the actuating lever (see Figure 3) to move it into the Raise position. Then, pump the handle by pulling it toward you until the base of the lift unit is raised the desired amount above the floor. The base can be raised a maximum of about 1 inch. Once the base is at the desired height, move the lever up to the Neutral position. The lift unit can now be maneuvered to the desired location. Once the lift unit has been positioned, the base should be lowered to the floor. The base is lowered by gently pulling up on the actuating lever to move it into the Lower position. The farther the actuating lever is pulled up the faster the base will lower to the floor. Remember, the base of the lift unit should always be lowered to the floor prior to lifting a vehicle.

Figure 3. Handle Operation

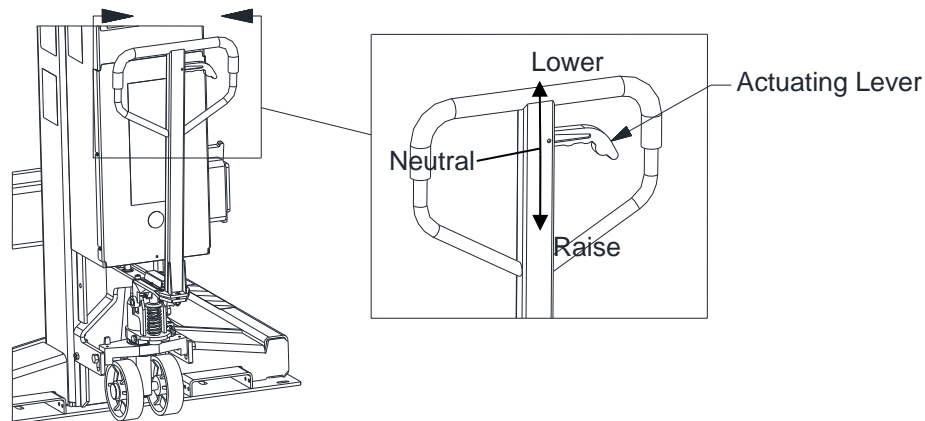

4.2 Moving the Lift Unit with a Forklift

You can move the lift unit by forklift, using the two forklift pockets (see Figure 4) provided on each lift unit. Be sure the forklift forks are fully inserted into the forklift pockets and the lift carriage is fully lowered before lifting. Use only these pockets to move the lift units with a forklift.

Figure 4. Forklift Pocket Locations

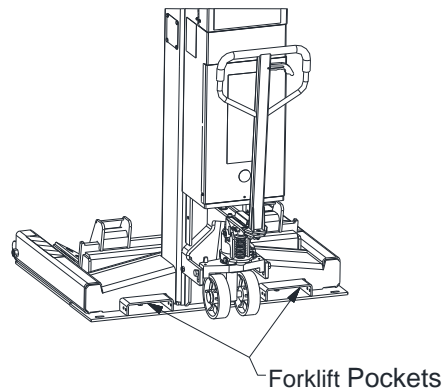

5. Battery Information

5.1 Battery Type

Each lift unit is equipped at the factory with two deep cycle batteries. These batteries have been selected to match the usage conditions found on the lift unit. If replacement batteries are needed, it is recommended to use only the same brand and model of batteries originally supplied with the lift unit. Do NOT mix old and new batteries or use different types/brands of batteries on the same lift unit.

5.2 Charging the Battery

The battery should be charged after each use to ensure the longest possible battery life and to avoid service interruptions. The batteries used on all lift system models can be charged before they are completely discharged and not develop a “memory”. The battery life and level of charge will be greatly improved if the batteries are charged before they are deeply discharged. **NOTICE:** *Only use the supplied battery charger to charge the batteries. The supplied battery charger is designed for the type of batteries used on the lift units. Use of a charger not designed for the type of batteries on the lift units may cause under or overcharging that will reduce the life and capacity of the batteries.*

The on-board battery charger is mounted inside the sheet metal cabinet above the door as shown in Figure 5. To charge the battery a suitable extension cord (see Table 1 below for proper cord selection) should be connected to the battery charger cord socket located on the left side of the lift unit. Always use a grounded extension cord with a plug style that matches the plug for the battery charger cord socket. Inspect the condition of the cord and plug and only use if they are free of defects. The amperage drawn by the battery charger is shown in Table 1. Eight lift units (in any combination of models) should be able to charge simultaneously on the same circuit powered by a 20 Amp circuit breaker.

Table 1. Extension Cords

Minimum Extension Cord Characteristics			
Length (ft.)	25	50	100
Wire Size (AWG)	18	18	18

Charger Input Requirements:
70-130 VAC @ 50-60 Hz & 1.3 Amps

The battery charger provided on each lift unit is a “smart” charger. There are two battery charger indicator lights (one for each battery) located above the door that indicate the status of the battery charger when it is plugged in (See Figure 5). The battery charger automatically goes through several different stages of

charging to properly charge the batteries and can be left plugged in at all times without harming the batteries. A solid red light indicates the charger is charging the battery. A solid green light indicates the battery is fully charged and the charger has switched to its maintenance charge mode. An orange light indicates the battery is connected with reverse polarity. To fix this error the charger leads need to be reversed on the battery so the correct polarity is observed. If both of the lights for one battery are flashing then an error condition exists. See Table 2 for help to fix the error condition.

Figure 5. Battery Charger

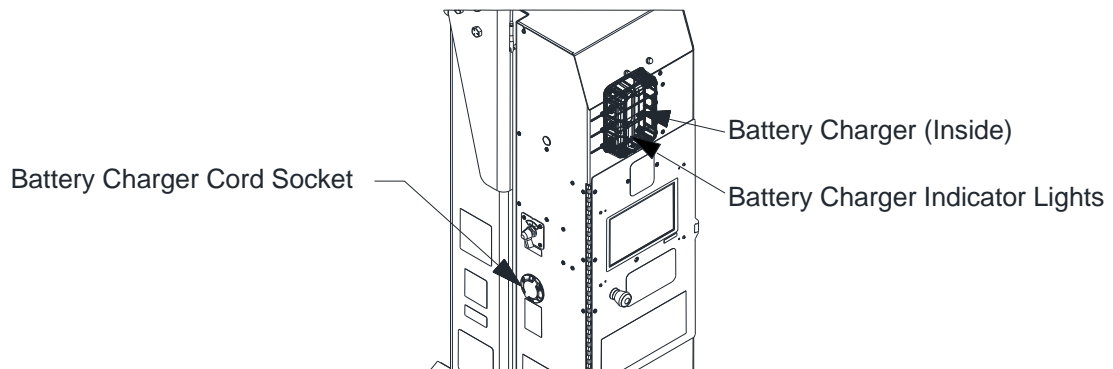

Table 2. Charger Error Descriptions

Possible Cause of Error	Description	Possible Fix
Low Battery Voltage	The battery voltage detected by the charger is below 2.0VDC	Check the battery voltage and remove the battery from the lift and charge it using a different charger to get the voltage above 2.0 VDC.
Abnormality Protection	The charger has been charging the battery for more than 80 hours without detecting a fully charged state.	Measure the battery voltage over time and if it does not increase then the battery is not charging correctly. Replace the battery if it is not charging correctly.
Blown Fuse	The fuse in the battery charger lead has blown.	Check charger leads for damage. Replace the blown fuse with an identical 15A blade fuse.
Corrosion on Battery Terminals	Battery terminals are corroded and preventing the charger leads from making a good connection.	Clean the battery terminals to remove any corrosion.
Loose Battery Connections	The charger leads are not tightly connected to the battery.	Tighten the nuts on the battery that secures the battery charger leads to the battery terminals. Torque battery nuts to 100-120 in-lb.
Damaged or Weak Battery	The battery is damaged or weak and cannot accept a charge.	Test the battery and replace if needed.

WARNING! The following warning statements are important for safe use of the batteries and the battery charger:

- ❖ Charge only batteries of the same type, voltage, cell number, and amp-hour capacities as shown on the label. Other types of batteries may burst causing personal injury and damage.
- ❖ To prevent electrical shock, do not touch either AC or DC uninsulated parts. Make sure all electrical connectors are in good working condition. Do not use connectors that are cracked, corroded or do not make adequate electrical contact. Use of a damaged or defective connector may result in a risk of overheating or electric shock.
- ❖ Lead-acid batteries generate explosive gases. To prevent arcing or burning near batteries, do not disconnect DC charging cord from batteries when the charger is operating. Keep sparks, flame, and smoking materials away from batteries.

- ❖ *Always shield eyes when working near batteries. Do not put wrenches or other metal objects across battery terminal or battery top. Arcing or explosion of the battery can result.*
- ❖ *Batteries produce hydrogen gas, which can explode if ignited. Never smoke, use an open flame, or create sparks near the battery. Ventilate the area when the battery is charging in an enclosed place.*
- ❖ *Lead-acid batteries contain sulfuric acid, which may cause burns. Do not get acid in eyes, on skin, or clothing. If contact with the eyes occurs, flush immediately with clean water for 15 minutes and obtain medical attention.*
- ❖ *Only a qualified service technician should program or service this equipment.*
- ❖ *Do not operate the charger if it has received a sharp blow, been dropped, or otherwise damaged. Have a qualified service technician examine and repair as needed.*
- ❖ *Do not disassemble the charger. Have the charger examined by a qualified service technician. Incorrect re-assembly of the charger may result in an explosion, electric shock, or fire.*
- ❖ *Use this battery and battery charger with the lift system only—NEVER use the battery and the battery charger for any other purpose. NEVER use an unapproved power source other than the battery to power the lift.*
- ❖ *DO NOT expose the battery charger to rain or snow.*
- ❖ *To reduce risk of damage to electric plug and cord, pull by the plug rather than the cord when disconnecting the extension cord from the battery charger cord socket.*
- ❖ *Make sure cord is located so that it cannot be stepped on, tripped over, or otherwise subjected to damage or stress.*
- ❖ *NEVER charge a frozen battery.*

5.3 Battery Life

Keeping the batteries properly charged will extend the service life of the batteries. Repeated deep discharging of the batteries will damage the batteries, reduce service life, and reduce the performance of the lift unit. It is recommended to charge the batteries as often as possible, especially over a weekend, to maintain the uptime of the lift system and ensure the longest service life possible from the batteries.

5.4 Battery Maintenance

If the lift unit is equipped with AGM type batteries no periodic battery maintenance is required. If the lift unit is equipped with wet cell type batteries the electrolyte level inside the batteries should be checked monthly. Prior to checking the electrolyte level the batteries should be fully charged (indicated by a solid green light on the battery charger). After opening each filler cap check that the electrolyte level is just below the filler tube in each cell. If any cell is found to have a low electrolyte level add distilled water to raise the electrolyte level until it is just below the filler tube.

5.5 Critical Battery Level Detected Message

Each lift unit is equipped with a circuit that automatically locks out the lift unit if the battery level gets too low to help prevent permanent damage to the batteries. When this lock out occurs a message of “Critical Battery Level Detected” will be displayed on the screen. If this message is shown the battery charger needs to be plugged in to recharge the batteries. Once the batteries have charged enough to allow the lift unit to operate again the “Critical Battery Level Detected” message will automatically disappear. At this point the lift unit will need to be reinitialized as described in Section 2.4. It may take over 30 minutes of charging before the message disappears and the lift unit is ready for use.

The same circuit that locks out the lift unit will also completely shut down the lift unit if the battery level remains low for a longer period of time. If a lift unit is ever found to be non-responsive and not able to start up normally it likely shut down due to a low battery level. Follow the steps in Section 2.13 to restart the control box.

6. Emergency Procedures

6.1 Emergency Stop

In the event that the system must be stopped immediately, the lift system has an emergency stop button located on the door just below the touch screen (see Component Identification on page 6). It is red in color and simply needs to be pushed in on any lift unit to halt a vehicle lift or lowering that may be in progress. The normal emergency stop condition will communicate with all lift units synchronized in the system to halt all lift units at once. After the situation is assessed, and it is determined that it is safe to continue lifting or lowering, the emergency stop button originally pushed in can be pulled back out and the **Reset** button pushed to reset the system. The **Reset** button must be pushed on the lift unit where the emergency stop button was activated.

In the unlikely event that the system would lose communication at the same time an emergency stop button is pressed and a lift unit is still moving, simply press the emergency stop button on the lift unit that is still moving. If this fails to stop the lift unit, turn the master on/off switch, located on the left side of the control enclosure (see Figure 5 on page 21), to the **OFF** position. If this is the case, then the motor starter solenoid has likely welded shut and will have to be replaced before manual lowering can occur. Contact the manufacturer for instructions on replacing the motor starter solenoid.

6.2 Manual Lowering

Any time the controls are found to not be functioning while a vehicle is already raised, the vehicle may be lowered to the ground using the following steps:

- a. Open the door on each lift unit. The door is held in place by a latch on the right side.
- b. Station a person at each lift unit.
- c. Each person must one at a time hold the manual raise/lower toggle switch down (see Figure 6). No motion should occur yet. If a lift unit lowers, release all manual raise/lower toggle switches, then verify all needle valves are closed (i.e., turned completely clockwise).
- d. Each person should slowly open the needle valve located on the power unit to begin descent while holding the manual raise/lower toggle switch down (see Figure 6).
- e. Coordinate the rate of lowering by adjusting the needle valve—counterclockwise is **FASTER** and clockwise is **SLOWER**. **Be sure to close all needle valves prior to the next use.**

If one or more lift unit(s) does not move down initially, it may be resting on the down stop catch pawl. Fully close the needle valve and slightly raise the carriage to clear the down stop catch pawl. The carriage is manually raised by pushing and holding the manual raise push button while also pushing up on the manual raise/lower toggle switch. Once the carriage is clear of the down stop catch pawl, lowering can resume.

Figure 6. Manual Control Components

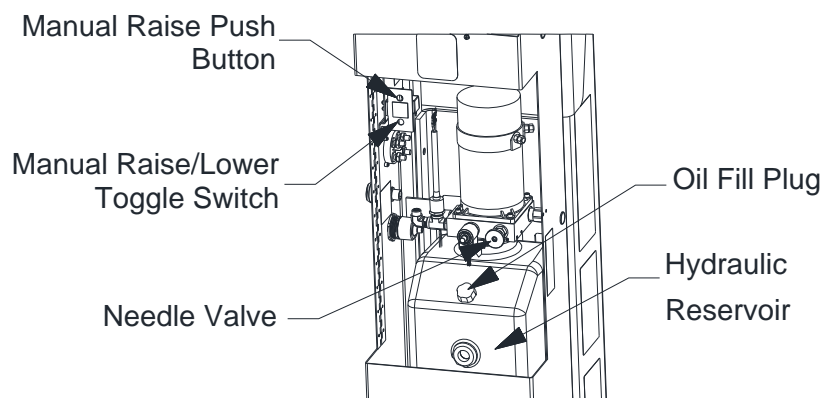

7. Lifting Multiple Vehicles in the Same Work Area

If you have 4 or more lift units in the same work area, it is possible to use them for separate lifting applications (e.g., lifting two different vehicles at the same time). Each set of lift units designated to work together to lift a particular vehicle is considered a lift system. Different lift units could be used in different lift systems at different times. For example, two units may be used as a lift system to raise the front end of a vehicle one day and those same two lift units might be used as part of a 4-unit lift system on another day.

When using multiple lift systems in the same work area:

- ❖ Identify the lift units to be used together in the lift system.
- ❖ Before raising the vehicle, make sure each lift unit in the lift system is fully lowered and the master on/off switch is turned to the **OFF** position. This will ensure that the lift system will know exactly how many lift units are part of the lift system and they will all be prepared to work together.

WARNING! *Failure to turn the master on/off switch to the **OFF** position could cause individual lift units to retain incorrect settings from previous lifts or to retain incorrect information from their use in previous lift systems.*

- ❖ During the control box initialization (see Section 2.4) make sure to select the same radio frequency and channel for all lift units in the system. Also, check the radio settings of all other lift units in the work area that are not part of the current lift system to make sure that no other lift systems (or any other individual lift units) are using the same frequency and channel.
- ❖ More than one lift system can operate on the same frequency as long as each system uses a different channel. Once a frequency is found that allows for operation with minimal signal loss faults, it is recommended to use the same frequency but different channels for all systems.

NOTE: The lift system's wireless feature complies with Part 90 of the FCC Rules. Lift system operation is registration-free and there are no licensing requirements for the end user.

8. Adjusting Carriage Width

8.1 Standard Width Models

The width of the carriage lift arms on the standard width models can be adjusted to fit a wide range of vehicles and tires. The width of the carriage lift arms is adjusted by positioning the lift arms in the series of notches on the front of the lift carriage. The width of the carriage lift arms must be adjusted as close as possible to the tread on the tire while remaining centered on the lift carriage. **WARNING!** *The lift arms must always be positioned so they are centered on the lift carriage. Positioning the lift arms in an off-center position can cause dangerous side loading of the lift unit.*

8.2 Wide Model

The wide model features a patented carriage width adjustment mechanism that allows the width of the carriage lift arms to be adjusted to fit a wide range of vehicles and tires. The width of the carriage lift arms is adjusted by turning either end of the carriage adjustment screw (See Figure 7). Each end of the carriage adjustment screw is hex shaped so a 1/2" wrench or socket can be used to turn it. **CAUTION!** *NEVER use an air impact wrench to adjust the width of the carriage lift arms. Use of an air impact wrench may cause damage to the adjustment mechanism that must be repaired before continuing service. Only use a wrench or hand ratchet to make adjustments.*

As either end of the carriage adjustment screw is turned, both carriage lift arms move in or out from the center of the carriage. The synchronized movement of the lift arms ensures that the load stays centered on the carriage and prevents dangerous side loading of the lift unit. The lift arms must be adjusted inward until the lift pads are within 1 inch (25.4 mm) of the tread on the tire.

Figure 7. *Wide Model Carriage Width Adjustment*

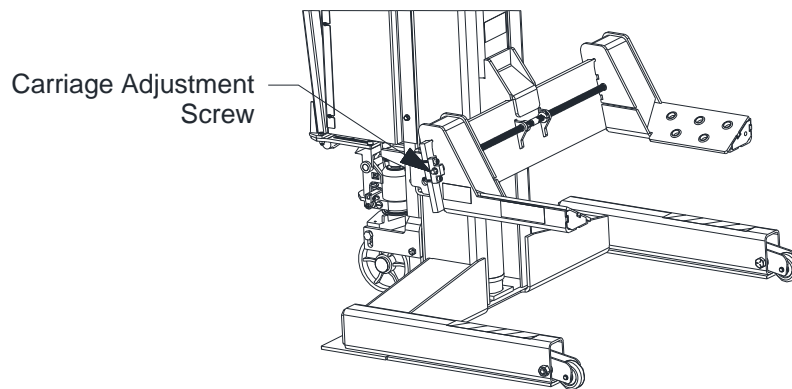

9. Maintenance Instructions

WARNING

All inspection and maintenance procedures must be performed *after* the equipment has been removed from service. Failure to heed this warning may result in personal injury and / or property damage.

9.1 Monthly Maintenance Requirements

- a. Check oil level in the oil reservoir. Refer to Section 9.2 below.
- b. All warning and capacity labels should be readable and complete. Wash external surfaces of lift unit, labels, and decals with a mild soap solution. DO NOT use a pressure washer to clean the control box. Contact the manufacturer for replacement labels as needed.
- c. Inspect battery terminal connections to make sure they are clean and residue free.
- d. Apply grease to the grease fittings for the down stop catch pawl (see Section 9.4) and check that it rotates forward and backward freely.
- e. Inspect structure for damage to contact surfaces, excessive wear, damaged or cracked welds and/or any abnormal conditions that could affect the performance of the lift units (see Section 10).
- f. **Wide Model Only:** Apply grease to the threads on the carriage adjustment screw.

9.2 Adding Hydraulic Fluid

The hydraulic reservoir is mounted inside the lower cover (See Figure 6 on page 23).

- a. The lift carriage must be in the fully lowered position and the lift unit must be on a level surface.
- b. Remove the lift unit from service and turn the master on/off switch to **OFF**.
- c. Open the door by releasing the latch on the right side.
- d. Clean around the surface of the oil fill plug to prevent contamination of the hydraulic oil system.
- e. Visually check the hydraulic oil level. The fluid level should be within a range from the bottom of the word “MONARCH” to 1” below the bottom of “MONARCH”. If the fluid level is low, remove the oil fill plug (see Figure 6) and add a high-grade hydraulic fluid equivalent to Phillips 66 Megaflo AW22 HVI. Do not overfill the reservoir. An air gap is required at the top for fluid expansion and to prevent spilling when moving the lift unit. **CAUTION!** *Do not use brake or transmission fluid. Use of the wrong fluid can deteriorate the seals and corrosion problems will occur.*
- f. Re-install the oil fill plug. Clean up any spilled oil and close the door. Test the lift unit for normal operation.

If the lift carriage does not rise to full height before the pump cavitates, check for air in the system. See Section 9.3 for instructions on how to bleed air from the hydraulic system. If this does not solve the problem, contact the manufacturer using the information on the back of this manual.

9.3 Bleeding Air from Hydraulic Cylinder

If the lift carriage is spongy or jumpy when either raising or lowering with no load, there is most likely air trapped in the cylinder. To remove the trapped air perform the following steps:

- a. Make sure there is no load applied to the lift unit.
- b. Open the door by releasing the latch on the right side.

- c. Raise the carriage by pushing up on the manual raise/lower toggle switch and pushing in on the manual raise push button (see Figure 6). Raise the carriage approximately two feet off the ground.
- d. Position a ladder behind the lift unit so you can reach the top of the cylinder. Use a 6 mm hex key to slightly loosen the vent screw (do not fully remove the vent screw) in the top on the cylinder, see Figure 8, while surrounding the port with a clean rag. You will hear the air escaping.

Figure 8. Cylinder Vent Screw

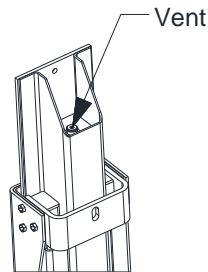

- e. When oil starts to escape past the vent screw, retighten the vent screw. It may take some time to purge all the air depending on the amount of air trapped in the cylinder.
- f. The air will now be purged from the system. Clean up any oil residue that escapes from the cylinder.
- g. When you get down from the ladder, lower the carriage by pushing down on the manual raise/lower toggle switch and opening the needle valve on the power unit (see Figure 6).
- h. To make sure no additional air gets into the system, the oil level in the hydraulic reservoir should be checked to ensure the reservoir has the proper oil level. Refer to Section 9.2 for more information.

9.4 Down Stop Catch Pawl Lubrication

If the down stop catch pawl is not rotating forward and backward freely it may be in need of lubrication as described in the steps below. **WARNING!** *If after lubricating the down stop catch pawl the pawl still does not rotate freely forward and backward DO NOT use the lift unit. Contact the manufacturer using the contact information on the back of this manual.*

- a. Open the door and locate the two grease fittings shown in Figure 9.
- b. Wipe the top of the grease fittings with a clean rag and apply good quality lithium grease to the grease fittings. Only apply 1-2 shots of grease to each fitting. Excessive greasing can cause the down stop catch pawl to operate slowly and is not recommended.
- c. Clean up any excess grease that is present.

Figure 9. Down Stop Grease Fittings

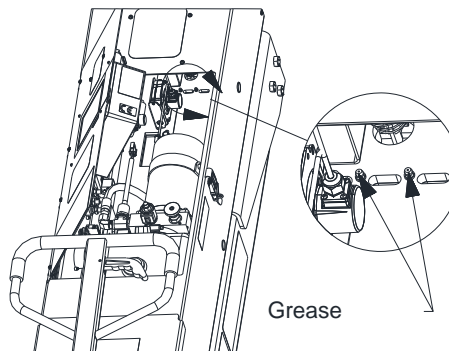

9.5 Down Stop Catch Pawl Adjustment

The down stop catch pawl position should only be adjusted if it is found to be outside of the adjustment range described below. The following steps describe how to check and adjust (if necessary) the down stop catch pawl position.

Checking the Down Stop Catch Pawl Position

- a. Turn the master on/off switch to the *ON* position.
- b. The green light shown in Figure 10 should be on.
- c. Open the door and push down on the manual raise/lower toggle switch (See Figure 6). You should hear the down stop catch pawl move backward, the yellow light should illuminate, and the green light should turn off while the toggle switch is held down.
- d. If the down stop catch pawl and the lights responded correctly, then no adjustment is necessary. Otherwise continue with the following steps to adjust the down stop catch pawl position.

Figure 10. Checking Down Stop Catch Pawl Position

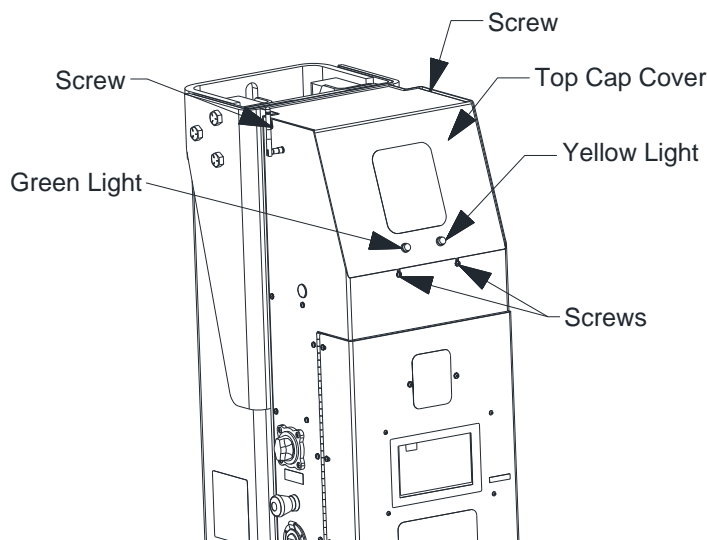

Adjusting the Down Stop Catch Pawl Position

- e. Disconnect the electrical connectors from the wires on the green and yellow lights. These wires are found inside the door behind the lights.
- f. Remove the top cap cover by loosening the 4 screws shown in Figure 10 and then lifting up on the cover to remove it.
- g. Loosen the 4 screws shown in Figure 11 holding the down stop solenoid in position so the solenoid can slide forward and backward.
- h. Rotate the down stop catch pawl backward toward the inside of the column (as shown by the arrow in Figure 11) until it touches the inside of the column. Hold the pawl in this position.
- i. Slide the down stop solenoid forward until a click is heard from the switch on the down stop solenoid. Once a click is heard the down stop catch pawl can be released.
- j. Tighten the 4 screws holding the down stop solenoid to lock it into position.
- k. Rotate the down stop catch pawl backward and make sure a click is again heard from the switch on the down stop solenoid.
- l. If a click is heard during Step k the down stop catch pawl position is correct. Reinstall the top cap cover. If a click is not heard during Step k repeat Steps g - k.
- m. Check the down stop solenoid positioning by following Steps a - d above to confirm the adjustment was completed successfully.

Figure 11. *Adjusting Down Stop Catch Pawl Position*

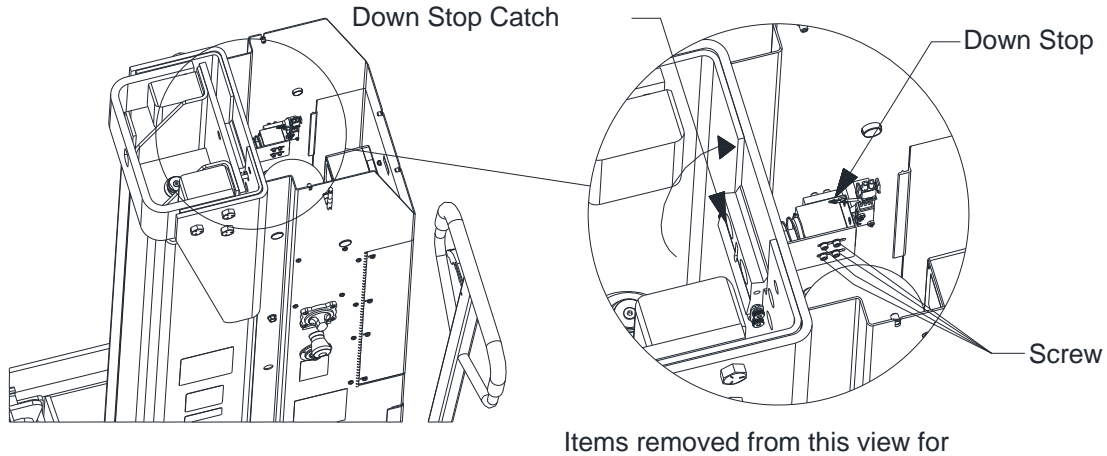

9.6 Carriage Width Adjustment Mechanism Lubrication (*Wide Model Only*)

The carriage width adjustment mechanism should be lubricated if the lift arms do not move inward and outward smoothly. Perform the following steps to lubricate the mechanism (See Figure 12):

- Apply grease to the threads on the carriage adjustment screw.
- Apply a thin film of grease to the surfaces shown in Figure 12 where the lift arms slide.
- Adjust the lift arms inward and outward after lubrication to help distribute the grease.

Figure 12. *Where to Lubricate Carriage Width Adjustment Mechanism*

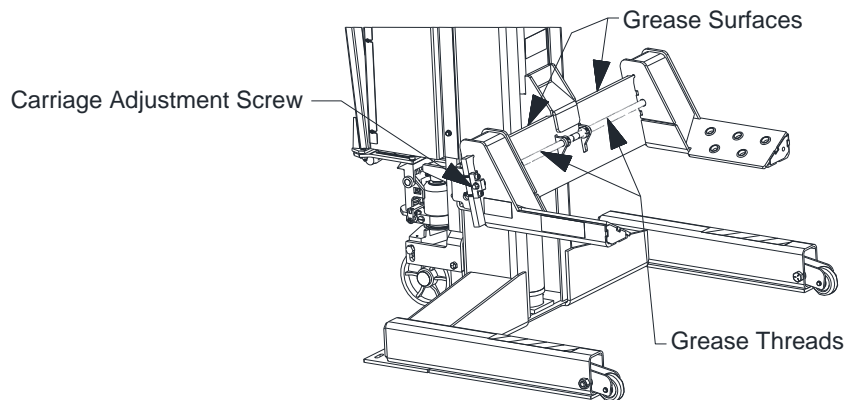

9.7 Electrical Fuses

The electrical system is powered by 12 VDC batteries capable of discharging up to 200 Amps to raise rated load. This electrical system does not need any routine maintenance, but there are several circuit protectors to be aware of.

⚠ WARNING

Always disconnect the battery from the system before changing fuses. Failure to heed this warning may result in personal injury and/or property damage.

- The battery charger is protected from a battery short circuit by 15 Amp ATC blade type fuses located in the charger leads near the battery terminals.
- Hydraulic power unit motor is protected by a 200 Amp ANL type fuse located inside the door mounted to a fuse block (see Figure 13, Item A).
- Down stop limit switch signal to control box is protected by a 3 Amp ATC blade type fuse. The fuse is installed in the furthest right slot of the fuse block located on the back side of the door (see Figure 13, Item B).
- Control box is protected by a 7.5 Amp ATC blade type fuse. The fuse is installed in the second slot from the right of the fuse block located on the back side of the door (See Figure 13, Item C).
- Down stop assembly circuit is protected by a 7.5 Amp ATC blade type fuse. The fuse is installed in the third slot from the right of the fuse block located on the back side of the door (See Figure 13, Item D).
- Control box screen charging circuit is protected by a 3 Amp ATC blade type fuse. The fuse is installed in the furthest left slot of the fuse block located on the back side of the door (See Figure 13, Item E).

NOTICE

Always replace fuse protective caps or covers after inspection of the fuse.

⚠ CAUTION

Always replace a blown fuse with the same size and type. An improper replacement could damage the equipment.

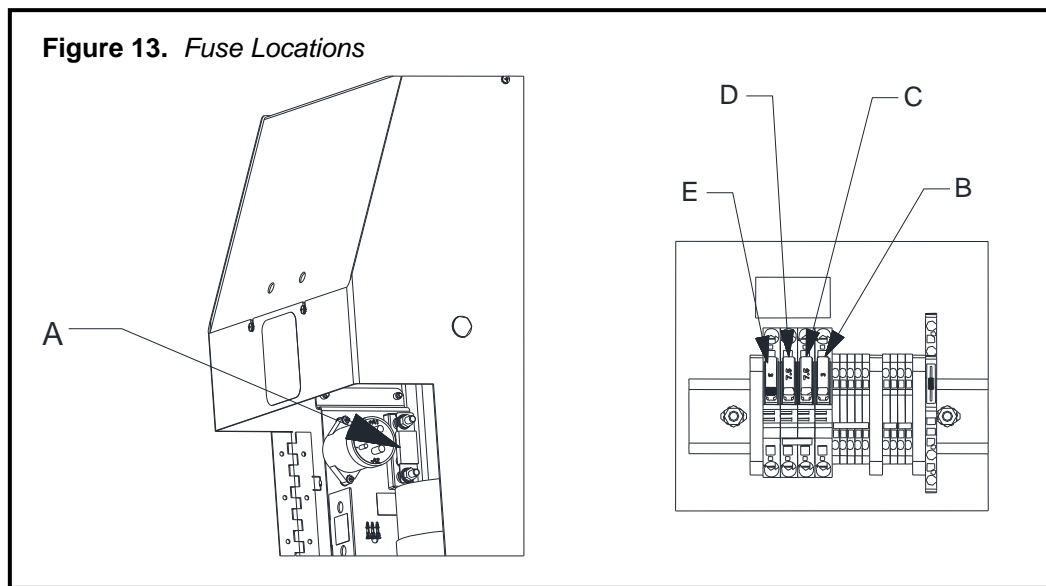

10. Structural Inspection

WARNING

Equipment must be removed from service and inspected for damage immediately if subjected to an abnormal shock or load. Failure to heed this warning may result in personal injury and / or property damage.

WARNING

It is critical that each lift unit be inspected regularly for any signs of wear or damage that might affect its ability to operate safely. Any lift unit that appears to be damaged in any way, is found to be badly worn, or operates abnormally must be removed from service until necessary repairs are made. Contact the manufacturer (using the information on the back cover of this manual) if you need to have a lift unit serviced or if you have any questions about how to address any wear or damage observed on a lift unit.

The employer, owner, and/or manager are responsible for maintaining the lift units in good, serviceable condition. Employees must be trained on how to inspect lift units. **Before each use** of a lift unit, the operator must visually inspect the lift unit for any abnormal conditions. Any lift unit subjected to an abnormal load or shock must be immediately removed from service and given a thorough inspection. The employer, owner, and/or manager must inspect (or appoint a knowledgeable person to inspect) each lift unit regularly. **Regular inspections** should be made **weekly** (if the lift unit is used daily) or **monthly** (if the lift unit is used only intermittently). Regular inspections should include the following:

- ❖ Check for any visual cracks, chips or other signs of excessive wear.
- ❖ Raise and lower the lift carriage through its full range (up and down)—it should move smoothly.
- ❖ Inspect the slide pad and roller contact surfaces for damage, such as gouging, warping, etc.
- ❖ All controls should operate smoothly and freely.
- ❖ Inspect the lift unit for oil leaks. If oil leaks occur, investigate and correct the source of the leakage (refer to Section 9.2 of this manual). **WARNING!** *Clean up any oil leakage immediately. Oil left on the floor can create a slipping hazard.*
- ❖ Inspect the down stop catch pawl to make certain it rotates forward and backward freely. If the catch pawl does not move freely it may need to be greased. Refer to Section 9 of this manual.
- ❖ Check the positioning of the down stop catch pawl. Refer to Section 9 of this manual.

If you are not sure whether any identified wear or damage is “serious”, DO NOT use the lift unit. The time it takes to determine whether or not the problem is “serious” or to repair the problem is small compared to the time it will take to deal with the consequences of a lost load (which could include severe injury or death to personnel).

11. Troubleshooting

The following pages are a list of fault messages that may be shown on the control box and possible solutions. If the solution listed fails to correct the problem, contact the manufacturer using the contact information on the back cover of this manual. Please have the model number and serial number of your lift unit and control box available. The lift unit serial number is on a permanently attached plate attached to the left side of the lift unit (Figure 14). The serial number of the control box is on the back of the control box. The door must be opened to see the control box serial number (See Figure 14).

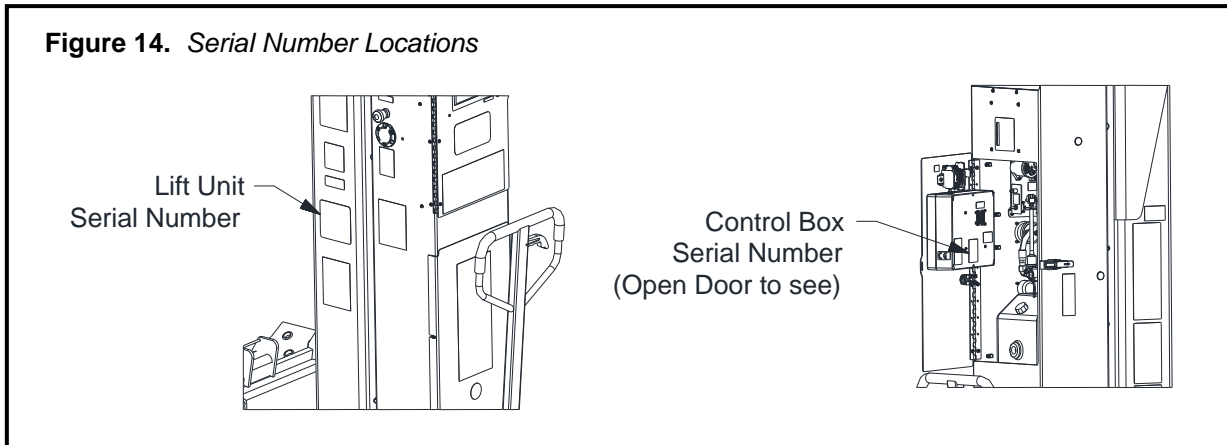

Control Panel Message	Meaning	Possible Solutions
Recharge Needed	<ul style="list-style-type: none"> • Energy level on one or more lift unit(s) has dropped below desired minimum – <i>recharge before next lift.</i> • Further use without recharge <i>could</i> shorten battery life. 	<ol style="list-style-type: none"> 1. Plug extension cord into battery charger cord socket to charge batteries.
Low Battery	<ul style="list-style-type: none"> • Energy Level on one or more lift unit(s) has dropped to a point where further lifting <i>will</i> damage battery. However, vehicle can be lowered. • Identified lift unit(s) <i>must</i> be recharged before further lifting can take place. 	<ol style="list-style-type: none"> 1. Plug extension cord into battery charger cord socket to charge batteries.
Max. Allowed Lift Height	<ul style="list-style-type: none"> • Lift system has reached the maximum height allowed for the present configuration of lift units. • Using only two lift units will raise 32” maximum. 	<ol style="list-style-type: none"> 1. Lift system may be lowered from this height.

<p style="text-align: center;">Signal Loss</p>	<ul style="list-style-type: none"> • Communication from one or more lift units was lost. • Can be caused by outside RF interference and is considered normal. • Communication link needs to be reestablished. 	<ol style="list-style-type: none"> 1. Check that the master on/off switch on all lift units in the lift system is still turned ON. 2. Wait a few minutes to see if interference clears and lift system is able to automatically recover. 3. If “Signal Loss” continues to reoccur, turn all lift units OFF, select another radio frequency several frequencies away, and re-synchronize the system. More than one lift system can operate on the same frequency as long as each system uses a different channel.
<p style="text-align: center;">Feedback Loop</p>	<ul style="list-style-type: none"> • Carriage position on one or more lift units is not responding properly to control box commands. • Carriage speed does not match control box output. 	<ol style="list-style-type: none"> 1. Press Reset button to continue. 2. If reoccurs, verify no obstructions with lift carriage. 3. If no obstructions, check operation of linear position sensor by observing the height readout on the display.
<p style="text-align: center;">Out-of-Sync</p>	<ul style="list-style-type: none"> • Lift units heights are not within acceptable synchronization range. • All lift units must be within 3” of each other to operate. 	<ol style="list-style-type: none"> 1. Press Reset button to clear fault. 2. Operate lift system in the opposite direction temporarily to re-synchronize. 3. If unable to re-synchronize, use manual lowering procedure and re-sync at ground level.
<p style="text-align: center;">E-Stop</p>	<ul style="list-style-type: none"> • Red emergency stop button has been pushed IN on one or more lift units. • All red emergency stop buttons must be OUT to operate. 	<ol style="list-style-type: none"> 1. Determine cause of activation. 2. Rectify condition and verify ready to operate. 3. Reset Emergency Stop Button and push Reset button to continue.
<p style="text-align: center;">Too Many to Lift</p>	<ul style="list-style-type: none"> • Number of lift units on the current radio frequency and channel is more than the operator input during set up. • Another lift system is already operating on the selected radio frequency and channel. • Number of lift units set to a given radio frequency and channel must equal the number input during set up. 	<ol style="list-style-type: none"> 1. Find all lift units not intended to be used on current vehicle. 2. If other units are being used on another vehicle, switch channels and re-synchronize. 3. If other units are to be idle, verify all units are OFF before synchronizing current system.
<p style="text-align: center;">Too Few to Lift</p>	<ul style="list-style-type: none"> • Number of lift units on the current radio frequency and channel is less than the operator input during set up. • Number of lift units set to a given radio frequency and channel must equal the number input during set up. 	<ol style="list-style-type: none"> 1. Push Reset button to clear fault message. 2. Find all lift units that are intended to be used and verify the master on/off switch is ON and the radio frequency and channel are correctly selected. 3. If all units are ON and the radio frequency and channel are correctly selected, turn all OFF and restart. Ensure proper number of lift units is

		input when prompted.
Down Stop Error	<ul style="list-style-type: none"> Down stop catch pawl on at least one lift unit is retracted while raising. All down stop catch pawls must be resting against the down stop plate before lift system will allow vehicle to raise. 	<ol style="list-style-type: none"> Lubricate down stop catch pawl. Check down stop catch pawl positioning. Contact the manufacturer for assistance if problem persists.
Raise Before Lower	<ul style="list-style-type: none"> Down stop catch pawl on at least one lift unit is not retracting properly. All down stop catch pawls must be fully retracted before lift system will allow vehicle to lower. 	<ol style="list-style-type: none"> Raise the vehicle slightly before lowering. This will also correct the fault if caused by the lift system being in Park mode. Lubricate down stop catch pawl. Check down stop catch pawl positioning. Contact the manufacturer for assistance if problem persists.
Park Error	<ul style="list-style-type: none"> Down stop catch pawl on one or more lift units in the system did not properly engage a down stop slot when the Park button was pushed. All units must park on a down stop slot within 10 seconds. 	<ol style="list-style-type: none"> Raise the vehicle a few inches and try to Park again. Lubricate the down stop catch pawl. Check the down stop catch pawl positioning.
Comm Error: SN	<ul style="list-style-type: none"> A different lift unit than what was initially setup with the lift system has attempted to communicate with the lift system. A new lift unit cannot be added to an existing lift system to replace an existing lift unit unless all the lift units are turned OFF and restarted. 	<ol style="list-style-type: none"> Turn OFF all the lift units and restart the lift system. If the problem persists, turn OFF all the lift units and restart on a different radio frequency or channel.
Single Mode Active	<ul style="list-style-type: none"> Single mode has been activated on the indicated lift unit. The lift system can only be operated from the lift unit where single mode was activated. 	<ol style="list-style-type: none"> When finished operating in single mode push the Auto Return button to level the lift system and return to operating the full lift system.
Paired Mode Active	<ul style="list-style-type: none"> Paired mode has been activated on the indicated lift unit. The lift system can only be operated from the lift unit where paired mode was activated. 	<ol style="list-style-type: none"> When finished operating in paired mode push the Auto Return button to level the lift system and return to operating the full lift system.

Model CLHM
Installation, Operation and Maintenance